

Action Target has a target for every shooter. See them all at Shop.ActionTarget.com/steel



REMEMBER SAFETY FIRST

1. Observe the NRA fundamental rules for safe gun handling.
2. Always wear wrap-around eye and ear protection.
3. Always shoot steel from the recommended distances.
4. Always use proper ammunition on steel targets*
5. Never use steel core or AP ammo on steel targets.
6. Review the Action Target Safe Steel Shooting Guide Shop.ActionTarget.com/steel_target_safety

*BASIC AMMUNITION REQUIREMENTS
 1/4" AR500 / rimfire ammunition at 10+ yards
 3/8" AR500 / handgun ammunition at 10+ yards
 3/8" AR550 / handgun at 10+ yards and centerfire rifle (<3000 fps) at 100+ yards (three notches on the edge indicate AR550)

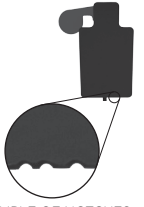

EXAMPLE OF NOTCHES

Limited Warranty

Action Target provides a limited warranty on its steel targets. The warranty can be found at Shop.ActionTarget.com/warranty.

For questions about this product contact technical support. TechnicalSupport@ActionTarget.com

Part #19917
 All rights reserved. Action Target, Inc.
 States and other countries. ©Copyright 2015.
 Trademarks of Action Target, Inc. in the United
 States and other countries. ©Copyright 2015.
 Action Target and its respective logo are

Always use safe
 shooting practices
 when shooting
 on steel targets.



BETTER EQUIPPED, BETTER PREPARED.™
 8802 West 35W Service Drive NE, Blaine, MN 55449-6740
 800.779.0182 / Shop.ActionTarget.com



PORTABLE TARGETS USER'S GUIDE / BASIC

THIS BOOKLET COVERS 35 TARGETS INCLUDING:

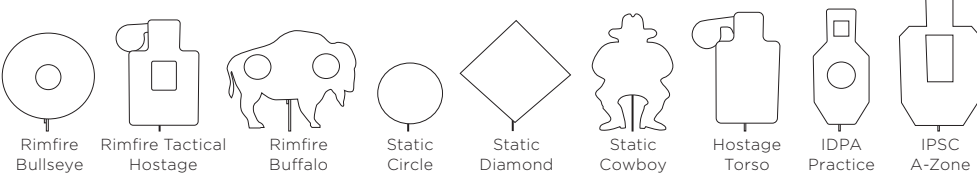

SEE THEM ALL
Shop.ActionTarget.com

PT STATIC STAND ASSEMBLY INSTRUCTIONS

Provided Parts

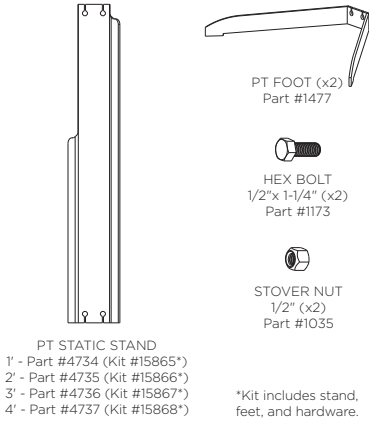

Step 1

Attach PT feet to PT static stand with the provided hardware on an even surface.

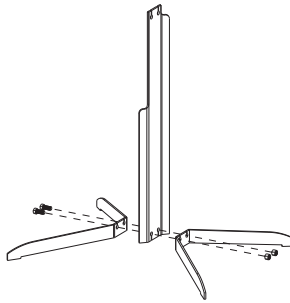

Step 2

With the front edge of the stand and the target plate facing the same direction, attach the target plate with the provided hardware. Leaving the hardware loose enough for the target plate to pivot. This movement more effectively dissipates impact energy.

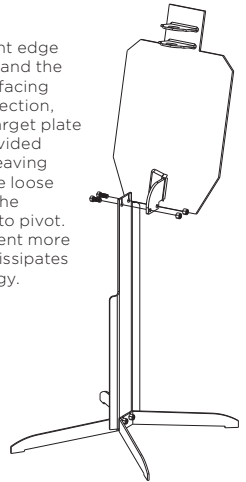

*Note: For even weight distribution, make sure the target plate is attached to the stand on the left side of the target plate bracket.

Needed Tools

3/4" Socket or Impact Wrenches

PT PRACTICE STAND ASSEMBLY INSTRUCTIONS

Provided Parts

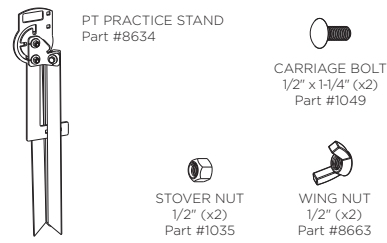

Needed Tools

3/4" Socket or Impact Wrenches

*You may use the Stover or wing nuts. Wing nuts don't need tools but require periodic tightening. Wing nuts are convenient if target plates are removed frequently.

Step 1

Hold the handle of the stand and open the legs outwards as far as they can extend.

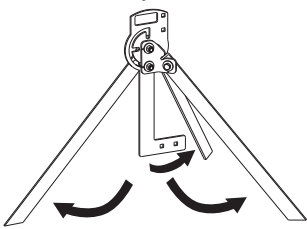

Step 2

Lower Position:

For a lower target position, rotate the neck 90° and push down to lock into place.

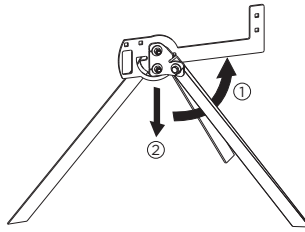

Step 3

Lower Position:

Attach the target head plate with the provided hardware* to the lower position near the handle.

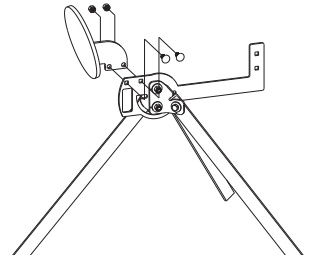

Higher Position:

For a higher target position, rotate the neck 180° and push down to lock into place.

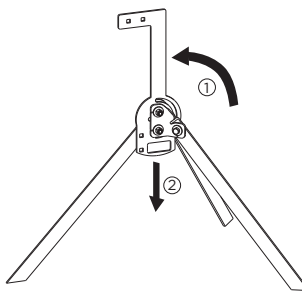

Higher Position:

Attach the target head plate with the provided hardware* to the higher position above the neck.

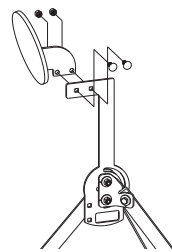

*Note: As with the static stand, do not over tighten the hardware and make sure the target plate is attached to the stand on the left side of the target plate bracket.

REACTIVE PLATE OPTIONS

Targets with Swinging Paddles

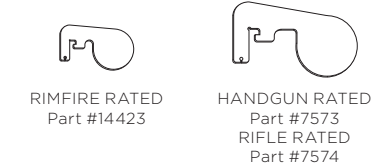

Step 1

Holding the swinging plate perpendicular to the target plate, insert it through the mounts on the target plate.

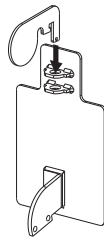

Step 2

To lock the swinging plate into position, swing it to either side.

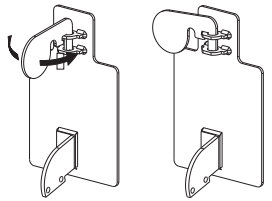

Heavy Duty Targets with Reactive Hit Zones

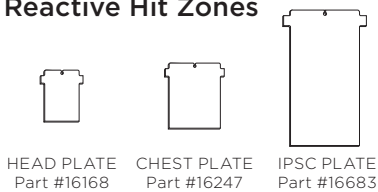

Step 1

Insert reactive hit zone plate into mounts of the target plate.

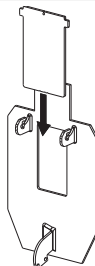

Step 2

Swing the reactive hit zone plate outward to situate it properly within the mounts.

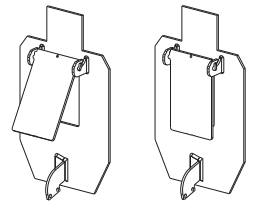

Rimfire Blue Targets with Reactive Hit Zones



Step 1

Insert retaining hinge through the mounts of the target plate.

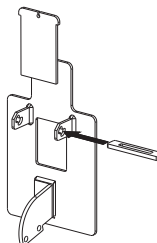

Step 2

Slide reactive hit zone plate into the retaining hinge.

